

## Weatherproof 14" x 10" x 4" Wireless Enclosure with 110 VAC Power Module

Model: NBP141004-100  
(HIC-NB6)

### Applications and Features

#### Applications:

- Remote Wireless LAN WiFi equipment installations
- Indoor and outdoor installations
- Corrosive environments
- Hotspot applications
- Protection of equipment from theft or damage

#### Features:

- Compact size
- Weatherproof ABS enclosure
- Easy to install
- Fully gasketed lockable raised lid
- 3 Rubber cable glands
- NEMA Type 3R / IP42 rated
- Removable 110 VAC power module
- Heavy duty Hook-and-Loop tape for mounting equipment in enclosure
- Ideal size for securing wireless access points



## Product Description

### Secure your wireless equipment...

Remote wireless equipment such as access points, routers and bridges [see below] often are more vulnerable to tampering and theft. This can disrupt and even cripple critical communications. A low cost solution for protecting and securing your wireless equipment is the NBP141004-100. This rugged, weatherproof composite enclosure is ideal for both indoor and outdoor applications. The compact size of this enclosure makes it ideal for locations with limited space requirements such as equipment closets or mobile applications. Also due to its size, the NBP141004-100 can be used where aesthetics are important, such as in offices and in public areas requiring HotSpots.

The 10.5" x 9.5" x 4" (266 x 241 x 101 mm) compartment features a removable power module with two 110VAC outlets. This power module has provisions to install two additional outlets. Cable access to the inside of the enclosure is via three rubber cable glands located on the bottom. Equipment can be mounted inside the enclosure either by using the included hook-and-loop tape or the four mounting stand-offs. The raised lid features a continuous gasket and a quick release latch with provisions for a padlock. The enclosure material is molded UV stabilized ABS. Three gasketed mounting holes are provided inside the enclosure for easy installations.

## Specifications

Model	NBP141004-100
Power Module Voltage	110 VAC
Enclosure Material	Molded UV Stabilized ABS
Enclosure Color	Gray
Weight	4 lbs (1.8 kg)
Outside Dimensions (max)	14.5 x 10.8 x 4.3 inches (36.8 x 27.4 x 10.9 cm)
Inside Dimensions	10.5 x 9.5 x 4 inches (26.6 x 24.1 x 10.1 cm)
Cable Feed	(3) 9/16" (14.2mm) Rubber Cable Glands
Ratings	NEMA 3R / IP42

**Enclosure Dimensions**

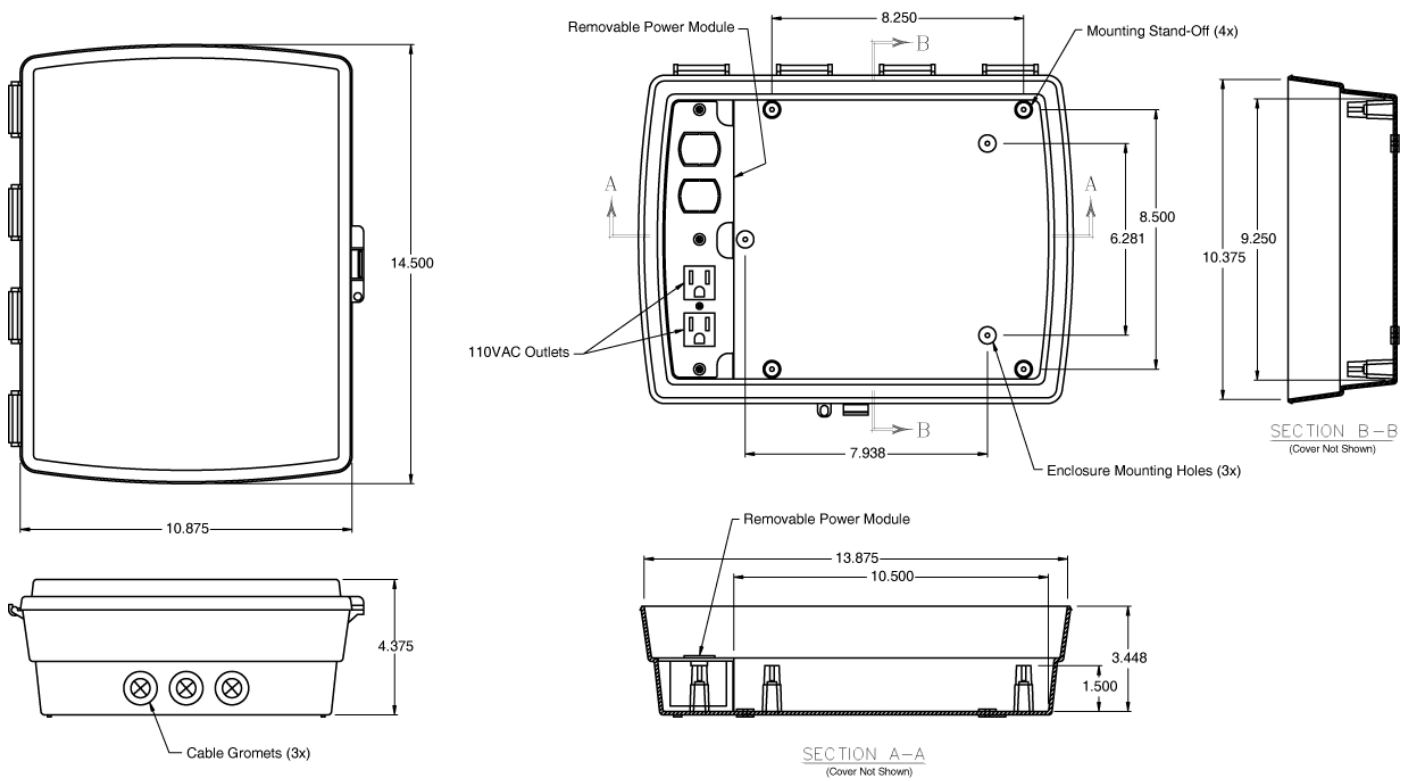

**Additional Enclosure Models**
**Enclosure Sizes:**

Model Options	Enclosure	Vented Enclosure	Enclosure with Heat	Enclosure with Cooling Fan	Enclosure with Cooling Fan & Heat
<b>110 VAC</b>	NB141207-100 NBP141004-100 NB181608-100	-	NB141207-1H0 NB181608-1H0	NB141207-10F NB181608-10F	NB141207-1HF NB181608-1HF
<b>Power-Over-Ethernet</b>	NB141207-400 NB181608-400	NB181608-40V	-	NB141207-40F NB181608-40F	-
<b>220 VAC</b>	NB141207-200 NB181608-200	NB181608-20V	NB141207-2H0 NB181608-2H0	NB141207-20F NB181608-20F	NB141207-2HF NB181608-2HF
<b>220 VAC (European)</b>	NB141207-E00 NB181608-E00	NB181608-E0V	NB141207-EH0 NB181608-EH0	NB141207-E0F NB181608-E0F	NB141207-EHF NB181608-EHF
<b>12 VDC</b>	NB141207-500 NB181608-500	NB181608-50V	-	NB141207-50F NB181608-50F	NB181608-5SF
<b>Sub-Zero Applications</b>	-	-	NB141207-4H0	-	-
<b>No Mounting Plate</b>	NB141207 NB121005 NB181608	-	-	-	-
<b>Mounting Plate</b>	NB141207-01 NB121005-01 NB181608-01	NB141207-00V NB181608-00V	-	-	-

 12" x 10" x 5" (30.4 x 25.4 x 12.7 cm), Part Number **NB121005-xxx**

 14" x 10" x 4" (35.5 x 25.4 x 10.1 cm), Part Number **NBP141004-xxx**

 14" x 12" x 7" (35.5 x 30.4 x 17.7 cm), Part Number **NB141207-xxx**

 18" x 16" x 8" (45.7 x 40.6 x 20.3 cm), Part Number **NB181608-xxx**

Model: NBP141004-100

**Configuration Examples**

---

**Shown with U.S.Robotics®  
USR5450 Access Point**



**Shown with Linksys® WAP54G  
Access Point**



**Shown with D-Link® AirPlus  
Extreme Wireless Router**

